

43/53 轴向安装充油耐震压力表PG-VR -043/053

43/53 Back mounting, Liquid filling & Vibration-proof pressure gauge PG-VR -043/053

产品特性：

径向结构、轴向、轴向卡子安装结构可选
 不锈钢旋紧式罩壳设计
 304 钢外壳铜内机、钢内机可选

充液耐震，密闭干式可选

2.5% 精度等级

测量范围：

铜内机：0.1MPa ~ 25MPa

钢内机：0.16MPa ~ 25MPa

平板卡子安装可选

CHARACTERISTICS

Bottom mounting, Back mounting, Back clamp mounting available

Stainless Steel, screw type

304 Stainless Steel case, brass internals or Stainless Steel internals available

Liquid filling, Vibration-proof, Obturation and dry type available

Accuracy 2.5%

Range

Brass internals: 0.1MPa ~ 25MPa

Stainless Steel internals: 0.16MPa ~ 25MPa

Plain board clamp mounting available

产品展示 Production	仪表类型 Types	型号标示(括号内填外径) Type code
径向 Bottom mounting : 43、 53  	铜内机干式 Brass internals, dry type	P - () .AO. 513 (YTN-)
	铜内机充液 Stainless Steel internals, liquid filling	PG-VR - () .AO. 513 (YTN-)
	钢内机干式 Stainless Steel internals, dry type	PG - () .AO. 513 (YTN-H)
	钢内机充液 Brass internals, liquid filling	PG-VR - () .AO. 513 (YTN-H)
轴向 Back mounting : 43、 53  	铜内机干式 Brass internals, dry type	P - () .ZO. 513 (YTN-Z)
	铜内机充液 Stainless Steel internals, liquid filling	PG-VR - () .ZO. 513 (YTN-Z)
	钢内机干式 Stainless Steel internals, dry type	PG - () .ZO. 513 (YTN-HZ)
	钢内机充液 Brass internals, liquid filling	PG-VR - () .ZO. 513 (YTN-HZ)
轴向卡子 Back clamp mounting : 43、 53  	铜内机干式 Brass internals, dry type	P - () .ZK. 513 (YTN-ZK)
	铜内机充液 Stainless Steel internals, liquid filling	PG-VR - () .ZK. 513 (YTN-ZK)
	钢内机干式 Stainless Steel internals, dry type	PG - () .ZK. 513 (YTN-HZK)
	钢内机充液 Brass internals, liquid filling	PG-VR - () .ZK. 513 (YTN-HZK)

几何尺寸 DIMENSIONS

单位 Unit (mm)

径向 Bottom mounting

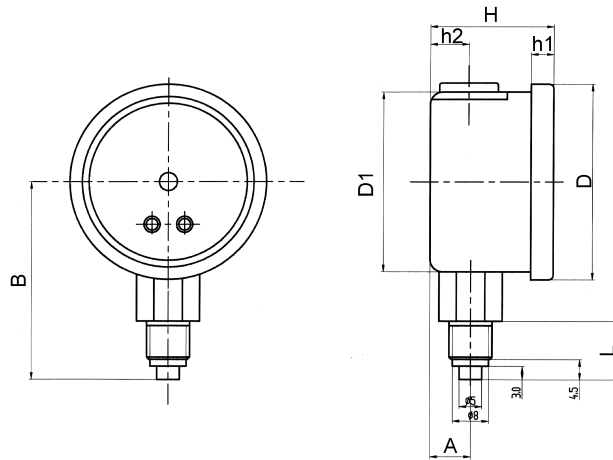

轴向 Back mounting

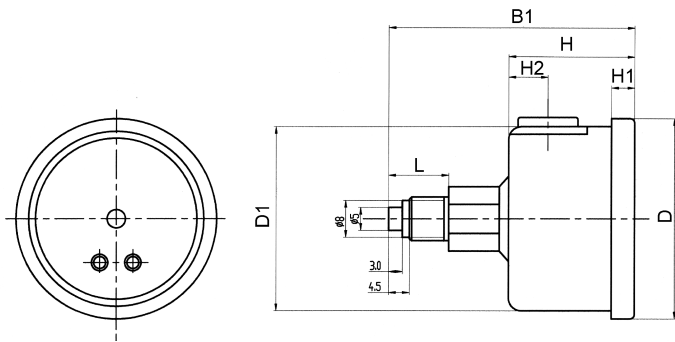

轴向卡子 Back clamp mounting

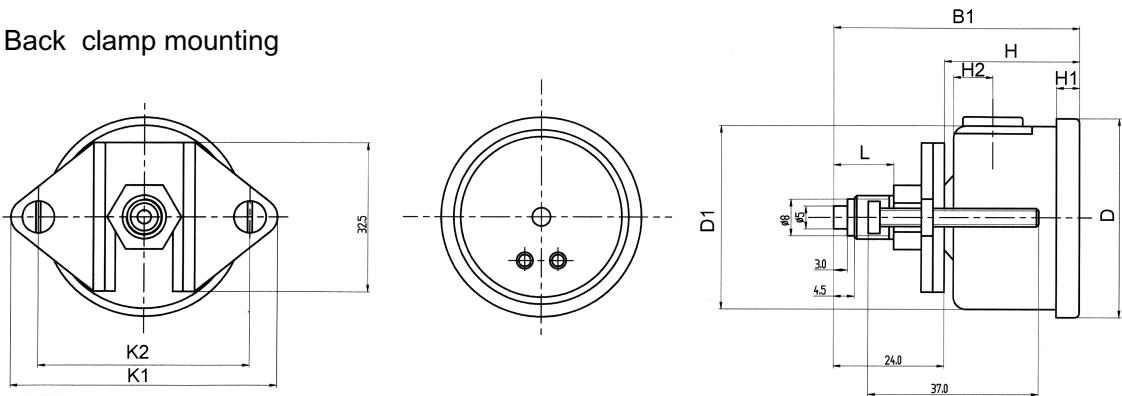

单位 Unit : mm

型号选择 Types available	D	D1	B1	L	H	H1	H2	K1	K2	B	A
() 043. AO. 513	43.5	40		13	29.5	5	8.5			44	9
() 053. AO. 513	53.5			13	29.5					47.8	9
() 043. ZO. 513	43.5	40	53	13	29.5	5	8.5				
() 053. ZO. 513	53.5	50	52	13	29.5						
() 043. ZK. 513	43.5	40	53	13	29.5	5	8.5	58	46		
() 053. ZK. 513	53	50	52	13	29.5			70	58		